

PART NUMBER	Plating
8656350067LF	0.4 μ Au
8656350067	0.4 μ Au
8656350065LF	0.76 μ Au
86563050065	0.76 μ Au
8656350064LF	flash Au
8656350064	flash Au

- NOTES:
- 1-Material: Phosphor bronze, thickness 0.20
socket : Phosphor bronze
 - 2-Finish on contact area: see table
finish on termination: bright tin lead over nickel
 - 3-Wire range: 20 to 28 AW
 - 4-Max outer dia of wire insulator:
-1.73 mm for contact #20-24
-1.02 mm for contact #24-28
 - 5-Current carrying capacity per contact:
5 Amps max when crimped to #20 AWG
5 Amps max when crimped to #22 AWG
3 Amps max when crimped to #24 AWG
2 Amps max when crimped to #26 AWG
1 Amps max when crimped to #28 AWG
 - 6-After 5 insertions into connector,
contact retention must be 5 pounds axial load min
 - 7-When contact is crimped to 20 AWG, the insulation support crimped height must be 1.78 mm max to ensure a proper insertion into housing
 - 6-Packaging: box of 500 contacts

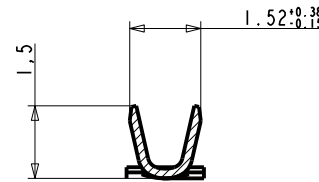

SECTION A-A

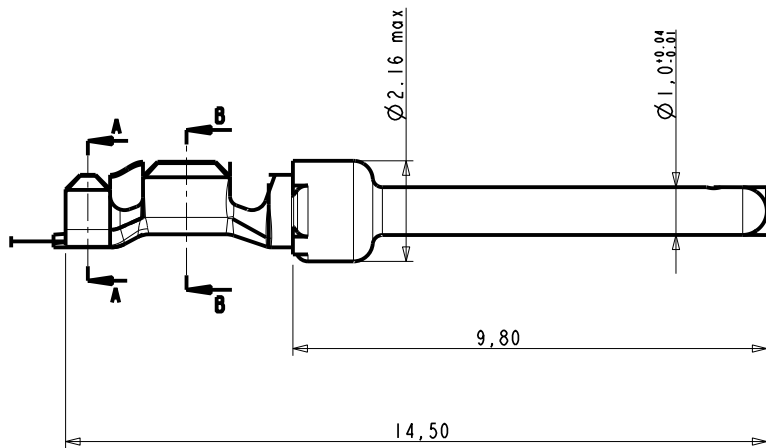
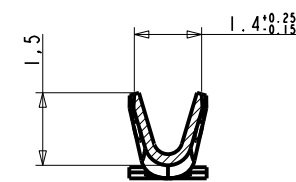

SECTION B-B

CROSS SECTIONS FOR CT #24-28



Copyright FCI.

NOTE : ROHS INFORMATIONS
The LF products meet European union directives and other country regulations as described in GS-22-008
Terminations plating spec : 2um Nickel min + 2um Sn min
Packaging Spec : see GS-14-920

rev	ecn no	dr	date
C	LS06-196	MPE	27/11/2006
D	LS08-0127	MPE	2008/05/13
E	LS08-0167	MPE	2008/08/05
-	-	-	-
-	-	-	-
-	-	-	-

www.fciconnect.com		surface - ISO 1302	tolerance std ISO 406 ISO 1101	projection ⊕	mm
		TOLERANCES UNLESS OTHERWISE SPECIFIED			
Dr	-	18/04/03	ANGULAR	size A3	Scale 5/1
Eng	-	-	LINEAR	ECN	LS08-0167
Chr	-	-	0° ± 2°	Product family	Spec ref
Appr	-	-			
FCI		title CRIMP PIN		dwg no C01-8656-1506	
		#Wire 24-28 Ø1.02		Rev. E	
		catalog no		sheet 1 of 1	

REV I - 2006-04-17